

BALCO INC

2626 South Sheridan • PO Box 17249 • Wichita, Kansas 67217
Phone: (316) 945-9328 • Fax: (316) 945-0789

INSTALLATION INSTRUCTIONS
FOR BALCO, INC. TRENCH AND ACCESS COVER

TST/ACT-X-250 W/LINER
FOR BLOCKOUT INSTALLATION

INSTALLATION INSTRUCTIONS FOR BALCO, INC. TST-X-250 & ACT-X-250 W/LINER TRENCH COVER & ACCESS COVER SYSTEMS FOR INSTALLATION INTO BLOCKOUTS

The following installation instructions are very important. Read them carefully, and be sure you understand them completely before you begin any work.

STORAGE & HANDLING

The trench cover system may require some assembly. Store this product in the horizontal position in a clean, dry location. This is a finished product. Store this product in a protected area. Do not stack anything on these stored Trench and/or Access Covers.

TST-X-250 & ACT-X-250 PARTS LIST¹

1. Frame
2. Liner²
3. Clip Anchors
4. Clip Anchor Bolts
5. Clip Anchor Screws
6. Cushions
7. Cover Plate
8. Cover Plate Bolts

¹ This system number is representative. The system number indicates cover plate surface finish, thickness, and width.

² The Liner is typically steel, but aluminum and stainless steel are also available.

TOOLS REQUIRED

This is a list of tools and materials recommended for use in the installation of these joint cover systems. These tools and materials are not provided by Balco, Inc.

- A. Electric Drill
- B. Drill Bits for metal (aluminum and steel)
- C. Drill Bits for drilling concrete.
- D. Sockets for hex head screws
- E. Phillip's Head Drill Bit
- F. Air Gun for clearing debris and dust from installation area
- G. Rivet Gun
- H. Silicone Sealant
- I. Caulk Gun
- J. Hammer
- K. Grout

INSTALLATION

These installation instructions are for use in the installation of Balco, Inc. TST/ACT-X-250 w/Liner Series Trench and Access Cover Systems for installation into blockouts. These instructions are for cast-in-place systems. The system is illustrated in Figure 1. These systems shall be installed as follows:

STEP 1. Review Balco, Inc. approved shop drawings for types and locations. Ensure that the blockouts are, at a minimum, the depth and width established in the trench cover details and that the trench is the proper length, depth, and width for the specified trench cover system. Ensure that the trench

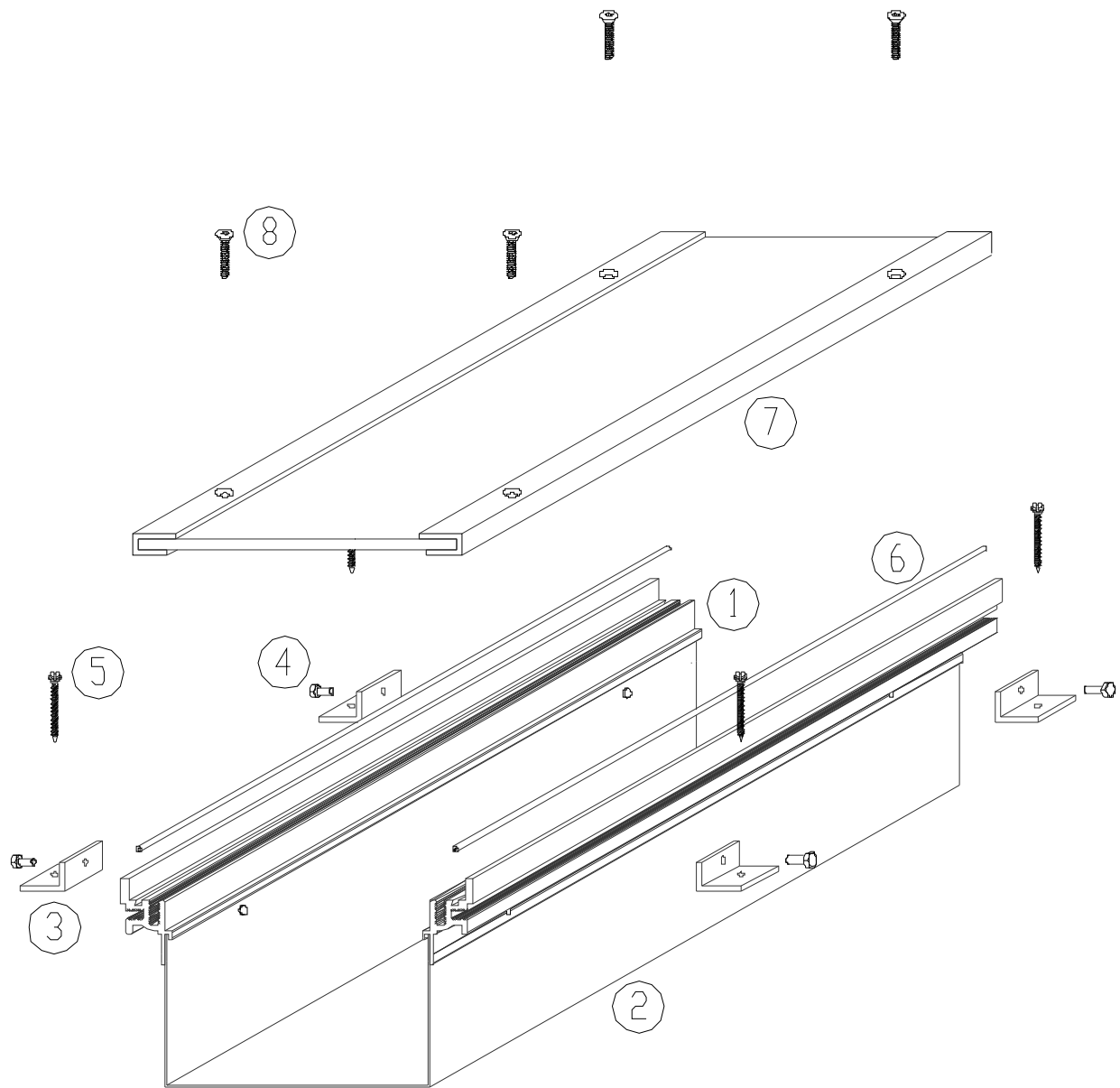

Figure 1

cover will be level and flush with the finished floor when it is installed, see Figure 2.

STEP 2. Select a frame section, the clip anchors and the clip anchor bolts. Attache the clip anchors to the frame using the clip anchor bolts, see Figure 3. Typical clip anchor spacing is 20" o.c. with an anchor a nominal 3" from each end of each frame section. **DO NOT OVERTIGHTEN THE CLIP ANCHORS.**

ISTEP 3. Completely assembly the trench cover system, installing all clip anchors and splices. Complete

the splicing of the liner and the frame as required. Refer to the section of these instructions entitled "SPlicing TRENCH AND ACCESS COVER FRAMES" and the section of these instructions entitled "SPlicing TRENCH LINERS" for procedures for assembling the frames and liners. Place the trench cover into the assembled frame. Ensure that the cover is properly aligned in the frame.

NOTE: TRENCH COVER SYSTEMS MUST BE INSTALLED FULLY ASSEMBLED TO ENSURE THE PROPER ALIGNMENT OF ALL THE SYSTEM COMPONENTS.

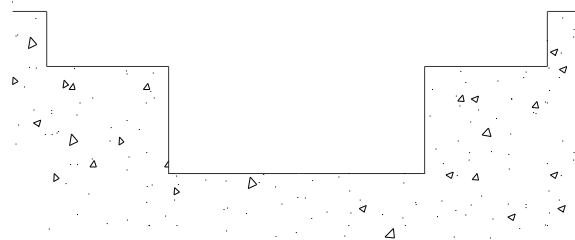

Figure 2

STEP 4. Place the assembled trench cover into its installed position in the blockout. Ensure that the trench cover assembly is in the proper position (level, the proper width, at the proper elevation, flush with the finished floor, and properly aligned and configured). Using the trench cover system as a template, mark the locations for the anchor holes on the substrate, see Figure 4. Remove the trench cover system from its installed position, and drill the anchor holes into the substrate at the marked locations.



Figure 3

STEP 5. Place the trench cover back into its installed position. Ensure that the trench cover is level, flush, and properly aligned. Using the fasteners provided by the factory, attach the trench cover system to the substrate, see Figure 5.

STEP 6. Remove the cover plate from the frame.

STEP 7. Caulk all splices, etc. with silicone caulk to provide additional moisture protection.

STEP 8. Place a temporary wooden cover (plywood is recommended) into the frame, attaching it to the frame as shown in Figure 6. This procedure is recommended to protect the cover plate from concrete splatter during the pouring and finishing of the concrete.

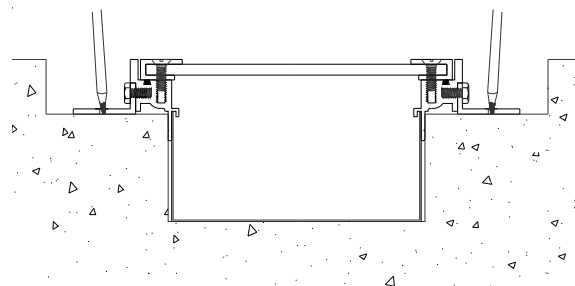

Figure 4

STEP 9. Place grout (by others) continuously between the trench cover system frame and the blockout,

see Figure 7. Install the grout in accordance with the grout manufacturer's written instructions.

STEP 9. Remove all excess grout from any exposed surfaces of the trench cover system before the grout sets up.

STEP 10. Remove the temporary wooden cover from the frame.

STEP 11. Place the cover plate back into its installed position on the frame. Attach the cover plate to the frame using the cover plate bolts, see Figure 8.

STEP 12. Install the tile into the cover plate recess at the time of installation of the finished floor (see Figure 9). Install the tile in accordance with the tile and adhesive manufacturers' instructions.

SPLICING TRENCH & ACCESS COVER FRAMES

Splice bars used to splice trench & access cover frames are fabricated by the factory. Splice bars are provided with factory drilled anchor holes.

STEP 1. Select a section of the trench cover frame and place it into its installed position. Ensure that the frame is level, the proper width, flush with the finished floor, and properly aligned.

STEP 2. Place a mating section of the frame into its assembled position relative to the frame section already put into place.

STEP 3. Abut the mating sections of the frame together as tightly as possible. Ensure that the system is level, even, the proper width, flush with the finished floor, and properly aligned.

STEP 4. Select a splice bar and place it into position on the frame so that the splice bar traverses the splice

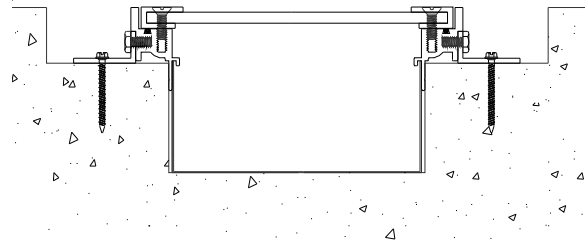

Figure 5

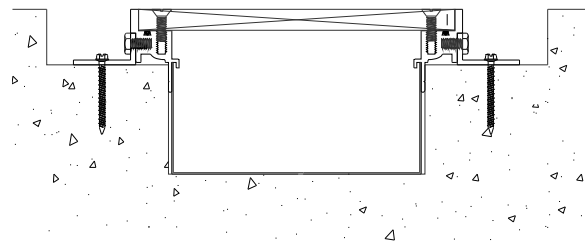

Figure 6

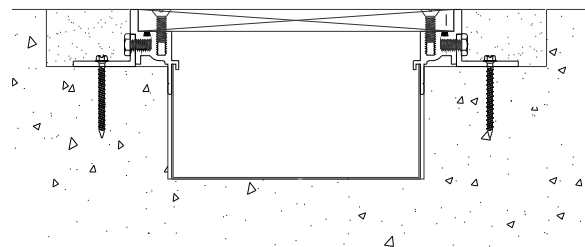

Figure 7

and so that the splice is centered behind the splice bar (see Figure 10).

STEP 5. Attach the splice bar to the to the frame sections using the fasteners (part no. H1412S) provided by the factory (see Figure 11).

STEP 6. Complete each splice in the frame using the procedures given in this section of these installation instructions.

STEP 7. Splice the trench liner in accordance with the procedures provided in this section of these installation instructions.

STEP 8. Complete the trench or access cover system installation in accordance with the procedures provided in these installation instructions.

SPLICING TRENCH LINERS

Splice plates for the trench liners are fabricate by the factory and are attached to the inside of one of the mating sections of the trench liner at the factory. The splice plates may be spot welded to the liner or they may be riveted to the liner. The splice plates extend beyond the section of the trench liner to which they are attached so that they can be inserted into the mating section of the trench liner. Trench liners are typically attached to the trench cover frames at the factory. Refer to the section of these instructions entitled "Splicing Trench & Access Cover Frames" for the procedures necessary to splice the trench cover or access cover frames.

STEP 1. Remove the sections of the trench cover plate from their corresponding sections of the trench cover frame and liner.

STEP 2. Select a section of the trench liner and place it into its installed position. Ensure that the liner is level, even, and properly aligned.

STEP 3. Place a mating section of the liner into its assembled position relative to the liner section already put into place (see Figure 12).

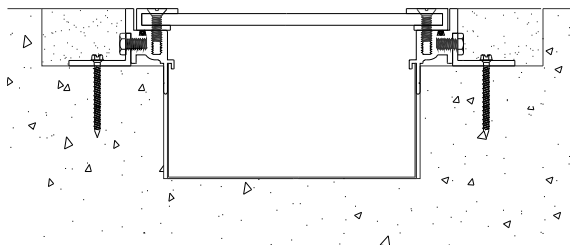

Figure 8

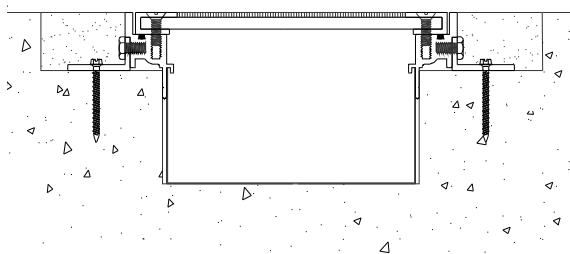

Figure 9

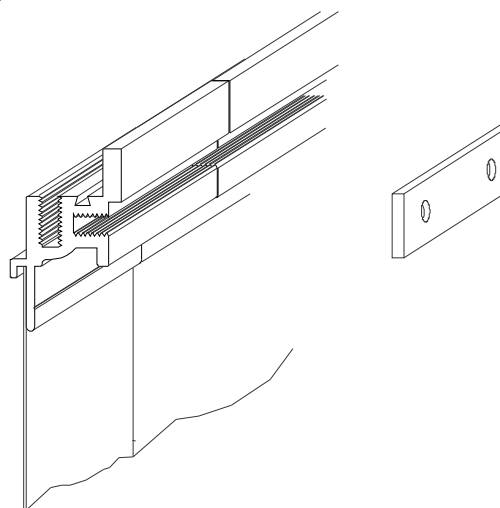

Figure 10

STEP 4. Place a continuous bead of silicone caulk (by others) on the exposed outside surface of the splice plate at a nominal 1" from the plate's end.

STEP 5. Slide the free end of the attached splice plate into the receiving end in the mating section of the trench liner (see Figure 13). Ensure that the mating sections of the trench liner are level, the proper width, and properly aligned. Ensure that the mating sections of the liner abut as closely as possible with one another.

STEP 6. Press the splice plate and the mating section of the liner together to spread the caulk and to form a better seal.

STEP 7. Caulk the splice with silicone caulk (by others) to provide additional moisture protection.

STEP 8. Spot weld or rivet the free end of the splice plate to the mating section of the trench liner, ensuring that the mating sections of the trench liner remain as tightly abutted together as possible (see Figure 14).

STEP 9. Repeat Step 3 through Step 8 of this section of these installation instructions for each subsequent section of the trench liner until the liner is completely assembled.

STEP 10. Splice the trench cover frames, as needed, in accordance with the appropriate procedures given in these installation instructions.

STEP 11. Complete the installation of the trench cover or access cover system in accordance with the procedures given above in these installation instructions.

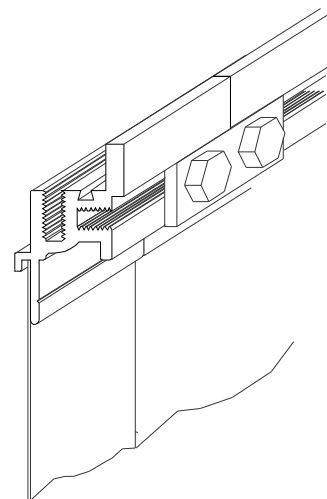

Figure 11

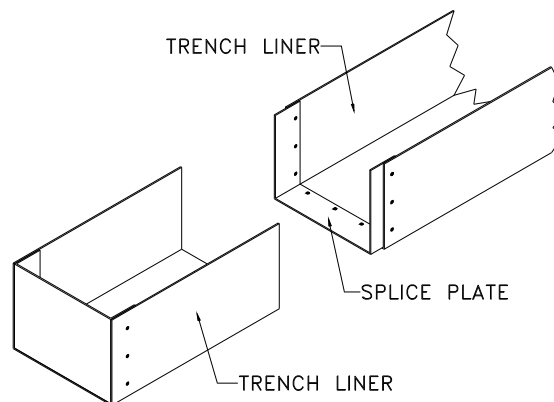

Figure 12

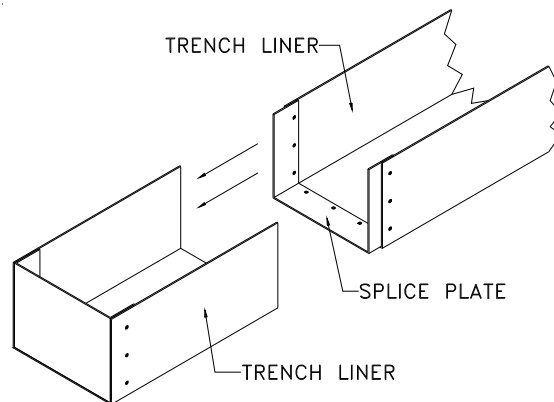

Figure 13

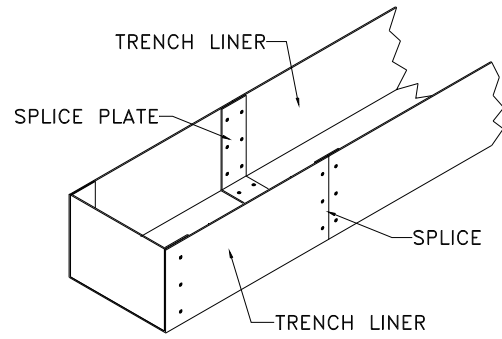

Figure 14

WARRANTY POLICY

Balco, Inc. warrants to its purchasers that all products sold by it will be free from manufacturing and material defects. Any defective product will be replaced or repaired free of any charge, provided a claim is brought to our attention, in writing, within the established warranty period following the date of shipment by us and provided our examination shows the product has failed under the terms of this warranty. The established warranty period for exterior joint cover systems (Duraflex™) is five (5) years provided the systems are installed by a Balco Certified Installer. The established warranty period for grids and mats is two (2) years. The established warranty period for all other Balco, Inc. products is one (1) year. Balco, Inc. will not be responsible for installation costs involved in such repair or replacement. Balco, Inc. shall have no obligation under this warranty if owner subjects materials to improper conditions (refer to Balco's installation instructions) This is in lieu of all other warranties, expressed or implied, and is the sole warranty extended by Balco, Inc. Our liability under this warranty is limited to repair or replacement and does not include any responsibility for consequential or other damage of any nature. It is further agreed and understood that the price stated for the seller's products is consideration for the limitation of seller's liability hereunder.

REGISTERED TRADEMARKS:

"VINYLLINES" "SAF-T-GLO"
"METAFLEX" "SAF-TEN BEVEL"
"SENTRY" "DURAFLEX"
"ILLUMI-TREAD"

BALCO, INC. PATENT NUMBERS:

5,357,727; 5,782,044; 5,829,216;
5,832,678; 6,014,848; 6,115,980;
6,581,347; 6,942,419; 6,955,017;
6,962,026; 7,104,717; 7,856,781
SAF-T-GLO patent pending