

***BALCO INC***

2626 South Sheridan • PO Box 17249 • Wichita, Kansas 67217  
Phone: (316) 945-9328 • Fax: (316) 945-0789

***INSTALLATION INSTRUCTIONS***  
***FOR BALCO, INC. TRENCH AND ACCESS COVER***  

---

***TSA/ACA-X-250 W/O LINER***  
***FOR CAST-IN-PLACE INSTALLATION***

# INSTALLATION INSTRUCTIONS FOR BALCO, INC. TSA-X-250 & ACA-X-250 W/O LINER TRENCH COVER & ACCESS COVER SYSTEMS

The following installation instructions are very important. Read them carefully, and be sure you understand them completely before you begin any work.

## STORAGE & HANDLING

The trench cover system may require some assembly. Store this product in the horizontal position in a clean, dry location. This is a finished product. Store this product in a protected area. Do not stack anything on these stored Trench and/or Access Covers.

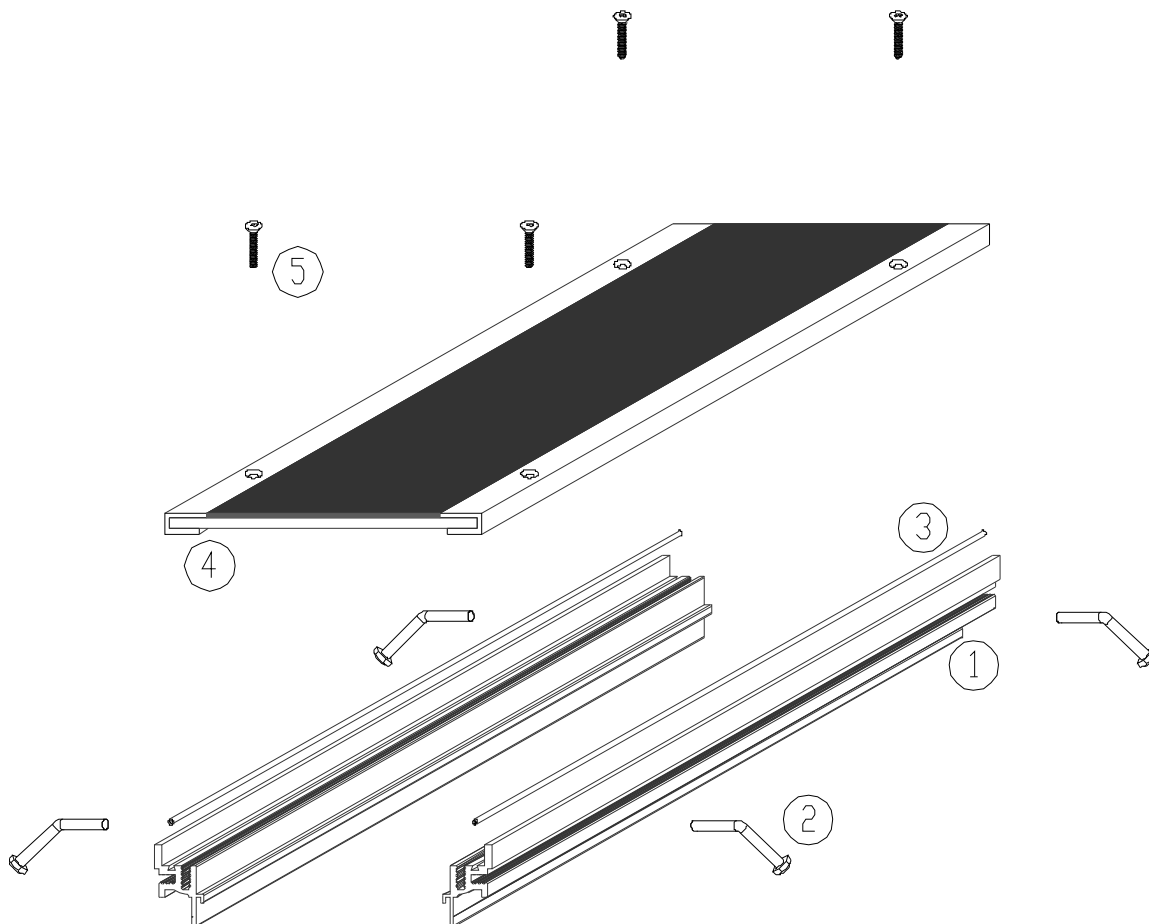

Figure 1

## TSA-X-250 & ACA-X-250 PARTS LIST<sup>1</sup>

1. Frame
2. Cast-In Frame Anchors
3. Cushions
4. Cover Plate
5. Cover Plate Bolts

<sup>1</sup> This system number is representative. The system number indicates cover plate surface finish, thickness, and width.

## TOOLS REQUIRED

This is a list of tools and materials recommended for use in the installation of these joint cover systems. These tools and materials are not provided by Balco, Inc.

- A. Wooden Bracing
- B. Plywood for temporary replacement of cover
- C. Electric Drill
- D. Drill Bits for metal (aluminum and steel)
- E. Drill Bits for drilling wood.
- F. Drill Bits for drilling concrete.
- G. Sockets for hex head screws
- H. Phillip's Head Drill Bit
- I. Air Gun for clearing debris and dust from installation area
- J. Rivet Gun
- K. Silicone Sealant
- L. Hammer
- M. Nails or wood screws for assembling bracing

## INSTALLATION

These installation instructions are for use in the installation of Balco, Inc. TSA/ACA w/o Liner Series Trench and Access Cover Systems. These instructions are for cast-in-place systems. The system is illustrated in Figure 1. These systems shall be installed as follows:  
**STEP 1.** Review Balco, Inc. approved shop drawings for types and locations.

**STEP 2.** Pour the concrete support pad, if required. Ensure that the support pad is the proper width, thickness, elevation, configuration, and length. Ensure that the top surface of the pad is level.

NOTE: BALCO, INC. RECOMMENDS THAT A CONCRETE SUPPORT PAD BE USED FOR INSTALLATION OF CAST-IN-PLACE TRENCH & ACCESS COVERS. HOWEVER OTHER



Figure 2

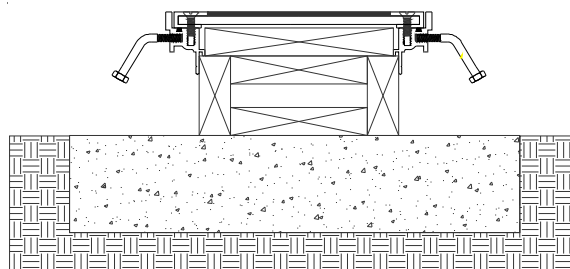

Figure 3

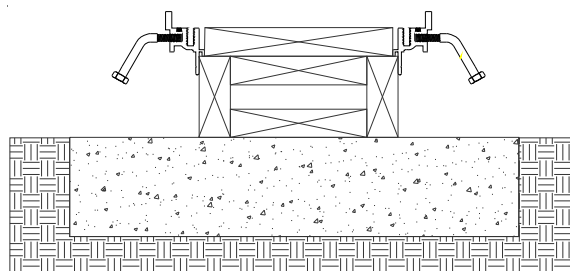

Figure 4

METHODS FOR INSTALLING CAST-IN-PLACE TRENCH & ACCESS COVERS MAY BE USED AND ARE ACCEPTABLE, PROVIDED THE SELECTED METHOD IS GOOD, STANDARD INDUSTRY PRACTICE AND PROVIDED THE SELECTED METHOD CONFORMS TO ALL APPLICABLE STANDARDS AND REQUIREMENTS.

**STEP 3.** Attach the anchors (part no. HB14212) to the trench cover or access cover frame, spacing the anchors at 20" o.c. (see Figure 2).

**STEP 4.** Completely assembly the trench cover system, installing all anchors and splices. Complete the splicing of the frame as required. Refer to the section of these instructions entitled "SPlicing TRENCH AND ACCESS COVER FRAMES" for procedures for assembling the frames. Place the trench cover into the assembled frame.

NOTE: TRENCH COVER SYSTEMS MUST BE INSTALLED FULLY ASSEMBLED TO ENSURE THE PROPER ALIGNMENT OF ALL THE SYSTEM COMPONENTS.

**STEP 5.** Attach the trench cover to the trench forms. (see Figure 3). Trench cover assemblies attached to trench forms may be wired or otherwise fastened to the forms.

**STEP 6.** Remove the cover plate from the frame (see Figure 4).

**STEP 7.** Caulk all splices, etc. with silicone caulk to provide additional moisture protection.

**STEP 8.** Place a temporary wooden cover (plywood is recommended) into the frame, attaching it to the frame as shown in Figure 5. This procedure is recommended to protect the cover plate from concrete splatter during the pouring and finishing of the concrete.

NOTE: IT WILL BE NECESSARY TO DRILL ANCHOR HOLES INTO THE TEMPORARY WOODEN COVER SO THAT IT MAY BE ATTACHED TO THE TRENCH COVER FRAME.

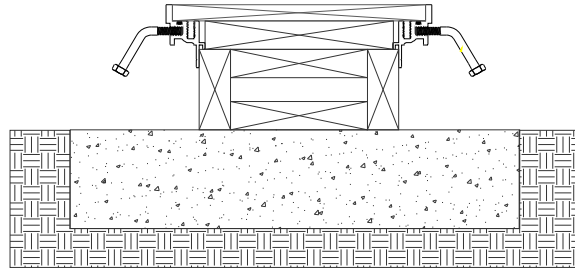

Figure 5

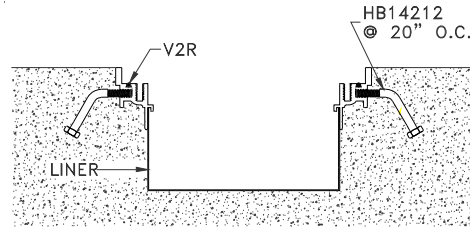

Figure 6

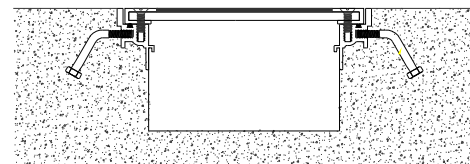

Figure 7

**STEP 9.** Ensuring that the trench cover or access cover assembly is in the proper position, that it is level, and that it will not shift during the pouring or finishing of the concrete, affix the assembly to the support pad. The assembly may be wired into place or otherwise affixed in place.

**STEP 10.** Pour the concrete in accordance with standard industry practice and all applicable requirements. Clean away any excess concrete from the exposed surfaces of the frame before the concrete is allowed to cure.

**STEP 11.** After the concrete has cured, remove the temporary wooden cover from the frame and remove the wooden bracing from the liner (see Figure 6).

**STEP 12.** Place the trench cover plate back into position in the frame. Ensure that each section of the cover plate is properly aligned and in the proper position.

**STEP 13.** Using the fasteners (part no F1434S) provided by the factory, attach the cover plate to the frame (see Figure 7).

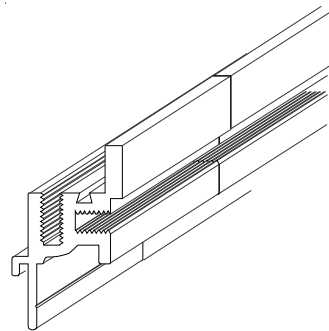

Figure 8

## SPLICING TRENCH & ACCESS COVER FRAMES

Splice bars used to splice trench & access cover frames are fabricated by the factory. Splice bars are provided with factory drilled anchor holes.

**STEP 1.** Select a section of the trench cover frame and place it into its installed position. Ensure that the frame is level, the proper width, flush with the finished floor, and properly aligned.

**STEP 2.** Place a mating section of the frame into its assembled position relative to the frame section already put into place.

**STEP 3.** Abut the mating sections of the frame together as tightly as possible (see Figure 8). Ensure that the system is level, even, the proper width, flush with the finished floor, and properly aligned.

**STEP 4.** Select a splice bar and place it into position on the frame so that the splice bar traverses the splice and so that the splice is centered behind the splice bar (see Figure 9).

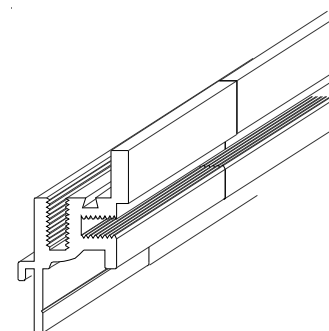

Figure 9

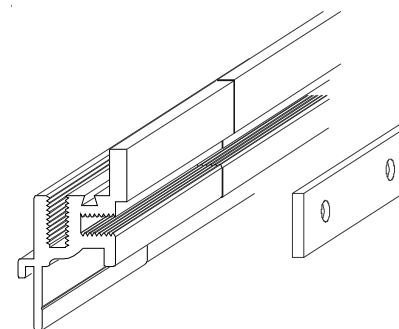

Figure 10

**STEP 5.** Attach the splice bar to the to the frame sections using the fasteners (part no. H1412S) provided by the factory (see Figure 10).

**STEP 6.** Complete each splice in the frame using the procedures given in this section of these installation instructions.

**STEP 7.** Splice the trench liner in accordance with the procedures provided in this section of these installation instructions.

**STEP 8.** Complete the trench or access cover system installation in accordance with the procedures provided in these installation instructions.

## **WARRANTY POLICY**

Balco, Inc. warrants to its purchasers that all products sold by it will be free from manufacturing and material defects. Any defective product will be replaced or repaired free of any charge, provided a claim is brought to our attention, in writing, within the established warranty period following the date of shipment by us and provided our examination shows the product has failed under the terms of this warranty. The established warranty period for exterior joint cover systems (Duraflex™) is five (5) years provided the systems are installed by a Balco Certified Installer. The established warranty period for grids and mats is two (2) years. The established warranty period for all other Balco, Inc. products is one (1) year. Balco, Inc. will not be responsible for installation costs involved in such repair or replacement. Balco, Inc. shall have no obligation under this warranty if owner subjects materials to improper conditions (refer to Balco's installation instructions) This is in lieu of all other warranties, expressed or implied, and is the sole warranty extended by Balco, Inc. Our liability under this warranty is limited to repair or replacement and does not include any responsibility for consequential or other damage of any nature. It is further agreed and understood that the price stated for the seller's products is consideration for the limitation of seller's liability hereunder.

### **REGISTERED TRADEMARKS:**

"VINYLINES" "SAF-T-GLO"  
"METAFLEX" "SAF-TEN BEVEL"  
"SENTRY" "DURAFLEX"  
"ILLUMI-TREAD" "METABLOCK"  
"MICHAEL RIZZA COMPANY"

### **BALCO, INC. PATENT NUMBERS:**

5,782,044; 5,829,216; 5,832,678;  
6,014,848; 6,115,980; 6,581,347;  
6,942,419; 6,955,017; 6,962,026;  
7,104,717; 7,856,781; 7,946,784;  
8,079,190; 8,245,471; 8,464,485;  
8,607,519; 8,601,760; 8,646,235;  
Fire Resistant Joint Covers Patents  
Pending