



2626 South Sheridan • PO Box 17249 • Wichita, Kansas 67217
Phone: (316) 945-9328 • Fax: (316) 945-0789

**INSTALLATION INSTRUCTIONS
FOR BALCO, INC.
CSL SERIES CHAMBERED SEAL
EXPANSION JOINT COVER SYSTEMS**



INSTALLATION INSTRUCTIONS FOR BALCO, INC. DURAFLEX™ CSL SERIES - CHAMBERED SEAL SYSTEMS

The following installation instructions are very important. Read them carefully, and be sure you understand them completely before you begin any work.

STORAGE & HANDLING

The expansion joint systems are shipped unassembled. Upon receipt, this product should be stored in the horizontal position in a clean, dry location. Store this product in a protected area. Store Balco, Inc. Primer 2, Balco, Inc. Tack Coat - TC12 and Balco, Inc. Elastomeric Concrete at 50°F - 95°F. Do not allow components of Balco, Inc. Primer 2, Balco, Inc. Tack Coat - TC12 or Balco, Inc. Elastomeric Concrete - EC11 to freeze. Balco, Inc. recommends that users wear insulated gloves, Neoprene or other appropriate material, safety glasses, long sleeve shirts and long pants. Ensure that the work area is well ventilated. The recommended shelf life for Balco, Inc. Primer 2, TC12, and EC11 is nine (9) months from the date of manufacture. All users should familiarize themselves with the Primer 2, TC12, and EC11 SDS information prior to the work.

CSL SERIES CHAMBERED SEAL SYSTEMS PARTS LISTS

	<u>CSL-250</u>	<u>CSL-325</u>	<u>CSL-400</u>	<u>CSL-500</u>	<u>CSL-600</u>
A. Elastomeric Seal	CS250	CS325	CS400	CS500	CS600
B. Wall Plate	CSLAP1A	CSLAP1A	CSLAP1A	CSLAP1A	CSLAP1A
C. Primer 2 ¹	Primer 2	Primer 2	Primer 2	Primer 2	Primer 2
C. Tack Coat ¹	TC12	TC12	TC12	TC12	TC12
D. Elastomeric Concrete ²	EC11	EC11	EC11	EC11	EC11
E. Fiber Pack ³	FP13	FP13	FP13	FP13	FP13
F. Adhesive Splice Kit ⁴	FSSK1	FSSK1	FSSK1	FSSK1	FSSK1

¹ Primer 2 and TC12 are two component products. Parts A and B for each are provided and are mixed by the installers at the job site.

² EC11 is a three component product. Part A, Part B and Aggregate are provided and are mixed by the installers at the job site.

³ Fiber Pack - FP13 is only provided for joints on inclined ramps. This product is not typically provided.

⁴ Optional Splice Kit. Provided if specifically ordered. Kit includes Primer, Brush, and Adhesive.

TOOLS REQUIRED

This is a list of tools and materials recommended for use in the installation of these joint systems. Tools and materials in this list are not provided by Balco, Inc. Tools and materials marked with an asterisk (*) must be pre-approved by Balco, Inc.

A. Hammer Drill	L. Air Compressor (fitted with an oil trap)
B. Drill Bits (for concrete and for metal)	M. Utility Knife
C. Phillips and Hex Drivers	N. Electric Drill
D. Tape Measure	O. Jiffy/Paddle Type Mixer
E. Level	P. Mixing Pails (1 gal. & 5 gal.)
F. Concrete Saw	Q. Spatula
G. Disc Grinder	R. Clean White Rags
H. Diamond Grinding Disc	S. Toluene
I. Hammer	T. Tape for masking substrate and seal
J. Concrete Patching Material*	U. Kraft Paper
K. Sandblasting Equipment	V. Paint Brushes or Rollers

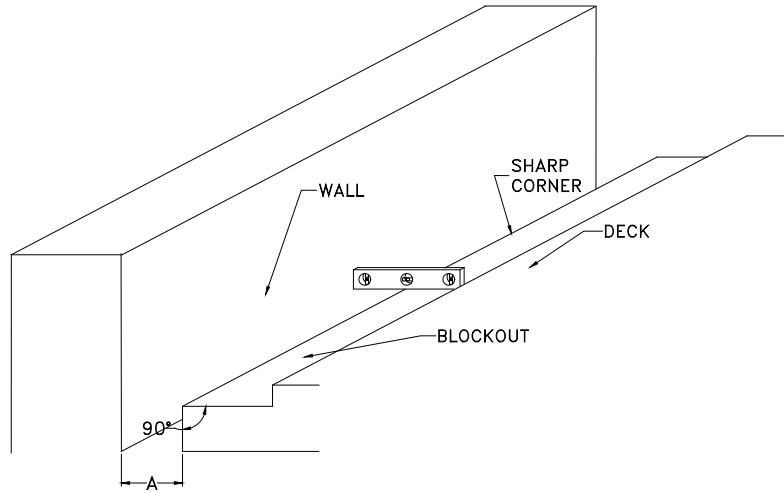

Figure 1

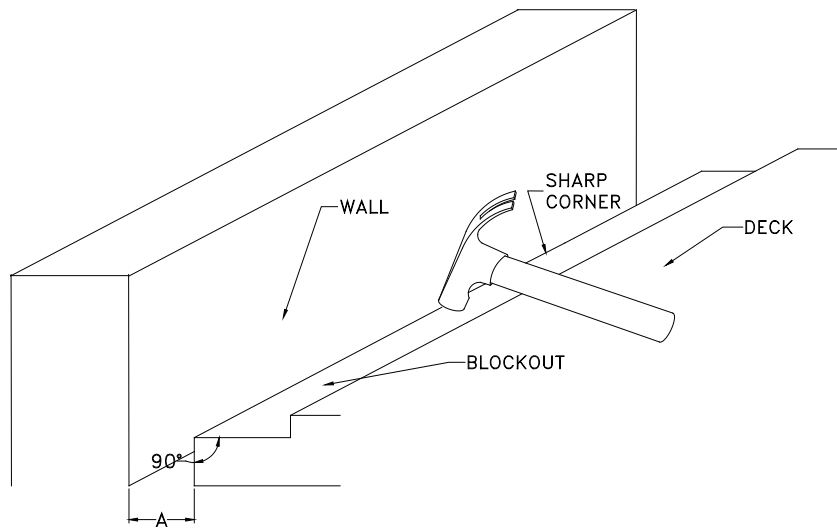

Figure 2

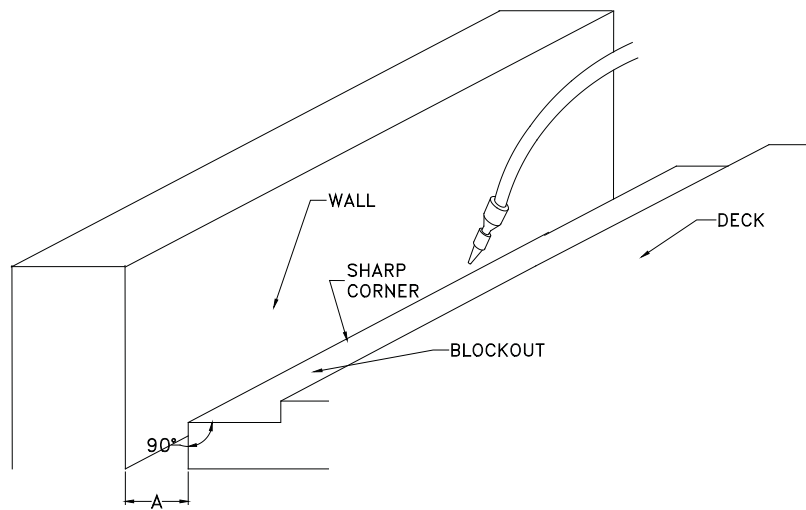

Figure 3

- | | |
|--|-----------------------------------|
| W. Trowels | Z. Splicing Iron or Hot Knife |
| X. Bulk-caulking Gun | AA. Plastic Sheet (4' 6" X 4' 6") |
| Y. Hack Saw w/ razor edge teeth (modified) | BB. Sealant |

PRELIMINARY REQUIREMENTS

1. Jobsite Conditions and Survey

The conditions of the joint opening must be surveyed prior to beginning installation work. The following points should be considered and action implemented where required:

- A. To select the proper seal size, measure the blockout and the joint opening at an ambient temperature of 70°F. The blockout size and joint opening should be verified and recorded by the Engineer of record. Correlate the joint opening measurements with the deck temperature. Verify that the opening width is synchronized with the values in the Temperature Adjustment Table supplied by the Engineer of record. Other movement requirements, such as longitudinal rack, deflection, etc. should also be considered and accounted for. Review all directional change locations; advise Balco, Inc. of the details.
- B. Verify that the deck and the base of the blockout are formed level and at the same elevation across the joint (see Figure 1). Report any areas exceeding +/- 1/4 inch to Balco, Inc. for instructions prior to commencing with installation of seal.
- C. Verify that the blockout and joint opening are constructed to the exact dimensions shown on Balco, Inc. shop drawings, straight, parallel and plumb. Concrete saws and diamond grinding disks should be used to correct any deviations.
- D. Verify that the joint interfaces are parallel to, and continuously equidistant from, each other and that they are straight and plumb. Verify that they are perpendicular to the base surfaces of the recess - making the corner a perfect "sharp" 90° angle (see Figure 1). It is critical that the leading corner on the base of the blockout, at the joint opening be a sound, square 90° corner. This ensures that the wing flange of the seal is fully supported.
- E. Slightly chamfered or rounded top corners (at the traffic surface) of the blockout are recommended. A tooled edge on the corners of the concrete is desired. The radiused edge reduces the effects of impact loading from vehicles and lessens the chance of edge erosion, cracking or spalling.

2. Blockout and Joint Opening Preparation

- A. Edge spalling, sharp projections and concrete voids (bug holes) shall be repaired prior to proceeding with the joint installation. Spalls in the concrete must be repaired using a patching material pre-approved by the Engineer of record. All repair materials used should have reached full cure conditions as specified by the repair material manufacturer. All obstructions such as form work and refuse shall be removed from the joint opening.
- B. Concrete within the blockout area and adjacent to the expansion joint system must be sound. Confirm by tapping these areas with a hammer (see Figure 2). A hollow sound, or cracking, crumbling or loosening of the concrete indicates it is unsound and must be removed and repaired with a structural repair mortar. Acceptable repair mortars include; Thoroc 1060, Emaco T-415 and Sika 123. Contact Balco, Inc. for recommendations on other compatible repair mortars.
- C. Areas that are repaired must also be sound and be confirmed by tapping these areas with a hammer. If a hollow sound is heard or the repaired area cracks, crumbles or loosens, the unsound

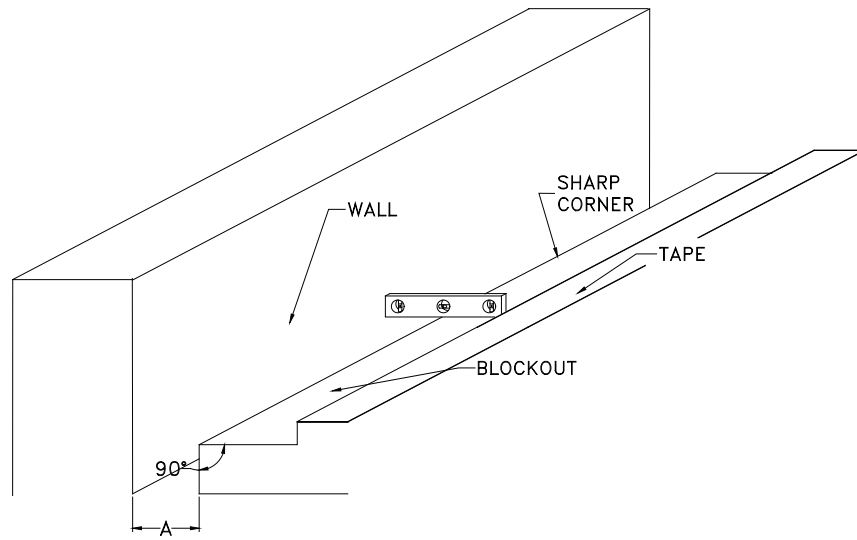

Figure 4

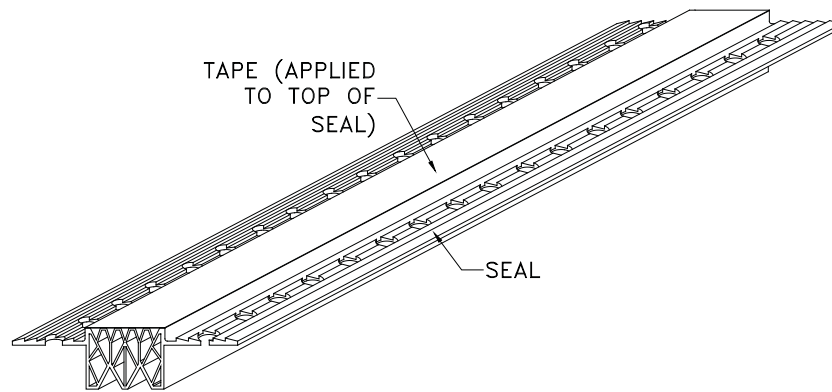

Figure 5

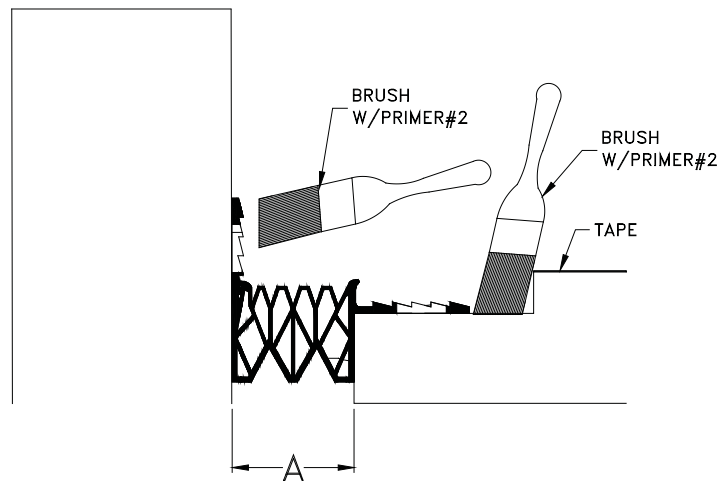

Figure 6

- repair must be completely removed and repaired again with a structural repair mortar. Access to the bonding surface of the interface walls must be free and clear. Any obstructions must be accounted for in the installation process.
- D. Ensure that the concrete is dry and fully cured. Balco, Inc. recommends either use of a concrete moisture meter to determine concrete moisture level or testing concrete cure in accordance with ASTM D4263, *Standard Test Method for Indicating Moisture in Concrete by the Plastic Sheet Method*. This test method uses a plastic sheet, 4' 6" X 4' 6", taped to the concrete. Fully cured concrete will have moisture content <3%.
 - E. The expansion joint blockout and opening should be sandblasted to remove laitance, loosely bonded material and any other contaminants, which may inhibit bonding of the system to the concrete (see Figure 3). Should sandblasting not be feasible, the surfaces must be ground with a coarse wheel disc grinder to produce an abraded surface. Care must be taken not to polish the concrete surface, as this can lessen adhesion. After sandblasting, or abrading, blow out the area with an air compressor fitted with an oil trap; this will eliminate the possibility of recontamination from oil and moisture in the lines.
 - E. Remove oil, grease and other contaminants with an approved solvent.

3. Steel Joint Opening Preparation

- A. For a joint lined with steel plates or steel angles, the steel surfaces must be sandblasted to a 'white metal' finish. Paint specification SSP-6 for cleaned finishes is an acceptable criterion.
- B. Use an air compressor fitted with an oil water trap to blow the area free of dust. Sandblasting is to be accomplished less than 2 hours prior to the installation of the seal. If the actual installation of the adhesive and seal exceeds this requirement, the steel must be cleaned again.
- C. Stainless steel surfaces must be prepared in the same manner as described above. Sandblasting is required.
- D. Galvanized surfaces must be sandblasted to a "white metal" finish. Paint specification SSP-6 for cleaned finishes is an acceptable criterion. Duct tape can be employed to protect surrounding areas. Only those areas to receive adhesive must have the galvanizing removed.

4. Seal Preparation

- A. The Winged Expansion Joint Seal shall be unrolled and allowed to lie in a relaxed position. Once relaxed the seal can be cut to length and any necessary splicing done (See section "Splicing"). The seal should be installed in the longest lengths possible to minimize splicing.
- B. Cut the seal to the lengths required for the application. Lengths should be accurate in order that the seal is not stretched during the installation process.

INSTALLATION

These installation instructions are for use in the installation of the DuraFlex™ CS Series Chambered Seal Systems Types CSL-250, CSL-325, CSL-400, CSL-500 and CSL-600. Do not mix or apply Balco, Inc. Primer 2, Balco, Inc. Tack Coat - TC12 or Balco, Inc. Elastomeric Concrete -EC11 at temperatures below 40°F. Balco, Inc. Elastomeric Concrete - EC11 will cure at temperatures down to 32°F. **DO NOT MIX PARTIAL BATCHES OF TC12 OR EC11.** Use the sand provided by the factory. Do not substitute sand. Do not allow the sand to become wet or damp. The sand must be dry at the time of mixing. Condition primer, EC11, and TC12 components, including aggregate, by storing them for 24 hours prior to use at a

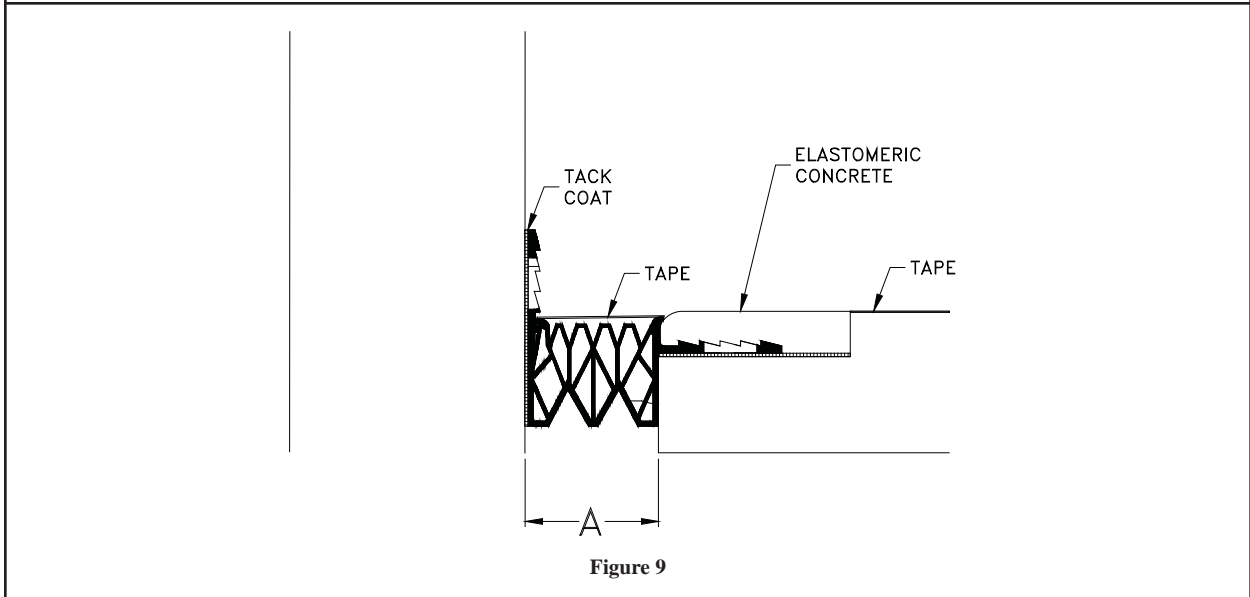
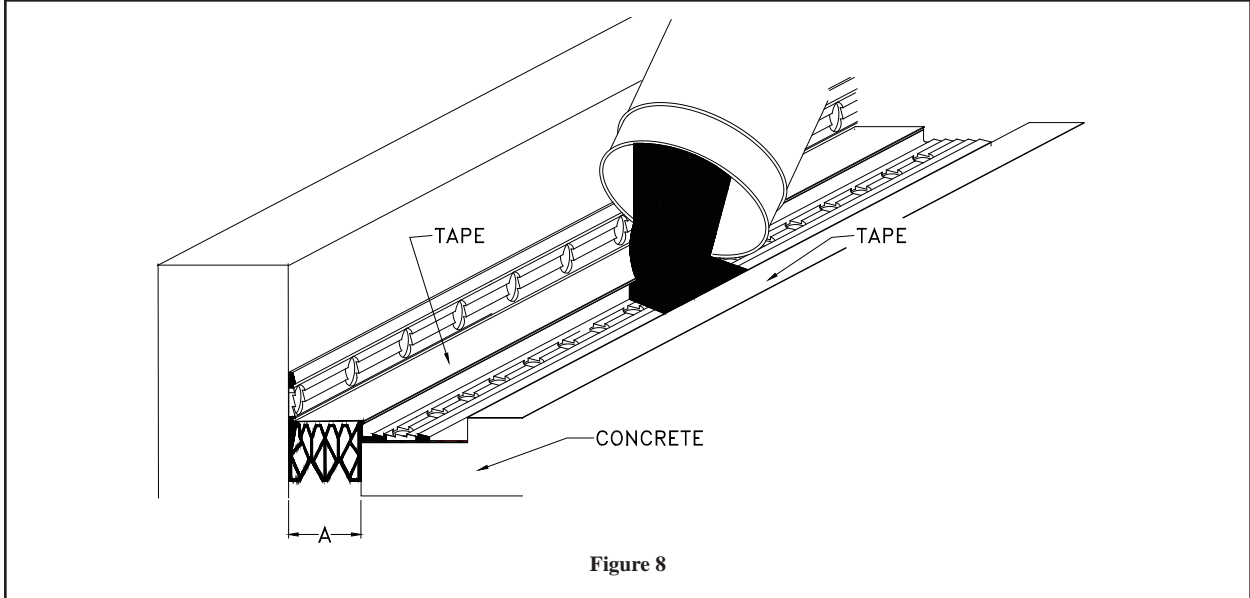
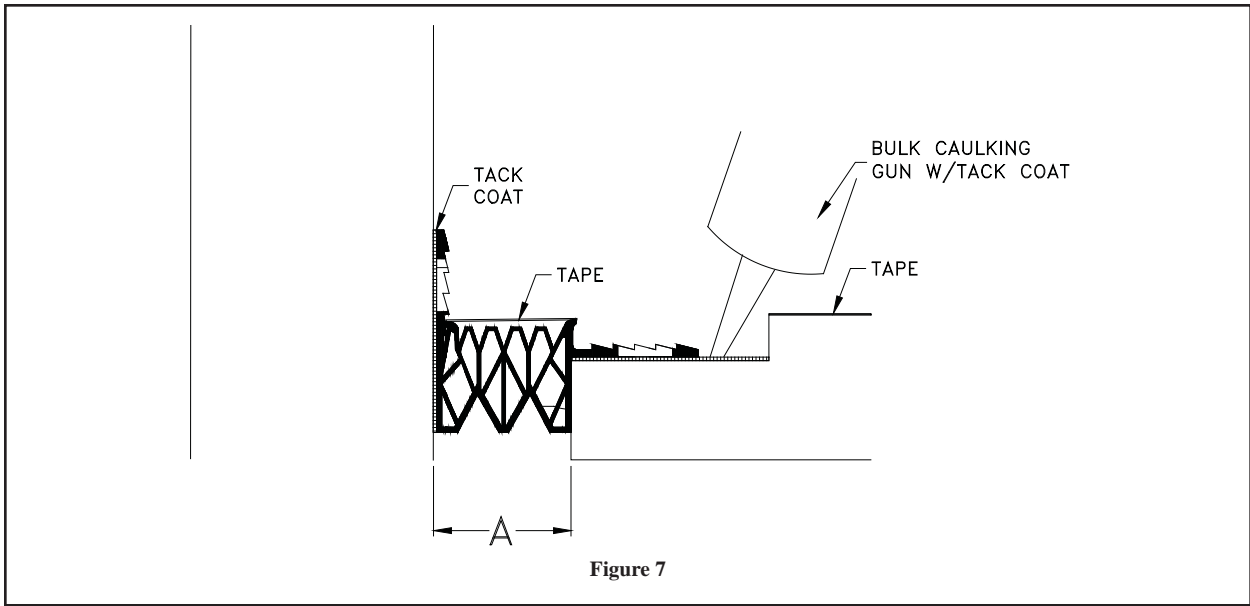

temperature range of 65°F - 85°F. Ensure that the concrete surface is dry at time of installation. The system shall be installed as follows:

- STEP 1.** Review Balco, Inc. approved shop drawings for types and locations. Ensure that the blockout, joint and surrounding concrete have been properly prepared for the seal installation in accordance with the section of these instructions entitled "Blockout and Joint Opening Preparation".
- STEP 2.** Apply masking tape to the deck surfaces adjacent to the blockout. Balco, Inc. also recommends that Kraft paper be used in conjunction with the masking tape to protect the concrete surfaces from tack coat and elastomeric concrete splatter, spills, tracking, etc. (see Figure 4).
- STEP 3.** Apply masking tape to the top of the seal to protect it from excess Tack Coat, Elastomeric Concrete and the collection of dust and grime during the installation (see Figure 5).
- STEP 4.** Wipe the sides and wings of the seal with a clean absorbent rag soaked in toluene. Ensure that the toluene does not spill onto and absorb into the concrete in the blockout, since this could have negative effects on the cure of the Tack Coat and the Elastomeric Concrete.
- STEP 5.** Insert the Winged Seal into the joint opening, ensuring that the wings fit tightly against the base of the blockout and against the facing wall.
- STEP 6.** Select a section of the wall plate. If the anchor holes have not been predrilled into the wall plates at the factory, mark the locations for the anchors on the wall plates. Standard anchor spacing is 20" o.c. with an anchor a nominal 3" for each end of the wall plate. Repeat this procedure for each section of the wall plate.
- STEP 7.** Thoroughly mix one unit of Balco Primer #2 (part A and B) and brush/roller apply to the horizontal and vertical surfaces of the blockout and to the portion of the facing wall under the seal wing (see Figure 6). Ensure that the Primer #2 does not puddle. Allow the Primer #2 to cure to a point where it is just dry. Typical coverage rate is 60 ft./unit.

NOTE: IF THE PRIMER DRIES FOR LONGER THAN 4 HOURS PRIOR TO THE APPLICATION OF THE BALCO ELASTOMERIC CONCRETE - EC11 INSTALLATION, THE AREA MUST BE RE-PRIMED WITH A MIXTURE OF PRIMER #2/MEK, 1:1 BY VOLUME.

- STEP 8.** Select the Balco Tack Coat - TC12, part A and B. Mix part B solids until part B is thoroughly mixed. Combine one liquid unit of Balco Tack Coat - TC12 part A and B in a 1 gallon pail, and briefly mix (approximately one minute) until they are fully blended. Typical coverage rate is 60 ft./unit.

NOTE: WORK QUICKLY. BALCO TACK COAT - TC12 HAS A WORK LIFE OF 15 MINUTES.

- STEP 9.** Using a bulk-caulking gun, immediately shoot the Balco Tack Coat - TC12 under the wings (see Figure 7). Place enough liquid so that it rises through the perforations in the wings. Push the wings down, if necessary, into the bonding liquid, then strike off excess material that has risen through the holes. It is important that the wings lie flat in the blockout and against the facing wall.
- STEP 10.** When the Balco Tack Coat - TC12 takes an initial set (becomes firm) the Balco Elastomeric Concrete - EC11 can be applied. You will need to start with a clean 5-gallon pail. Pour one unit of Balco Elastomeric Concrete - EC11 liquid part B into the clean pail and briefly mix (5-10

seconds) with a heavy-duty drill and paddle. Add one unit of Balco Elastomeric Concrete - EC11 liquid part A into the part B and briefly mix (5-10 seconds) with a heavy-duty drill and paddle. Immediately and progressively add the pre-measured graded aggregate (Balco EC11 Aggregate) and blend into the liquid until all components are fully mixed.

STEP 11. Pour the Balco Elastomeric Concrete - EC11 into the blockout and trowel smooth from the upper outer ridge of the seal to the blockout corner (see Figure 8). Ensure that the Elastomeric Concrete - EC11 is level and that it extends above the seal approximately 1/4".

NOTE: THE BALCO ELASTOMERIC CONCRETE - EC11 HAS A SHORT POT LIFE; IT MUST BE MIXED QUICKLY AND IMMEDIATELY APPLIED. TYPICAL COVERAGE RATE FOR EC11 IS 15 FT./UNIT. WORK QUICKLY. EC11 WORKING LIFE IS 15 MINUTES.

STEP 12. Champfer the edge of the Elastomeric Concrete along its interface with the seal. As needed, level off the Elastomeric Concrete and trowel the finish smooth. Trowel the surface flush with the top of the deck (see Figure 9). For best results, use a trowel that is wiped in an approved solvent. This will prevent the Elastomeric Concrete from building up on the trowel and provide a smooth finish.

STEP 13. Immediately after placement of the Balco Elastomeric Concrete, remove the masking tape from the seal and concrete and dispose of the used tape properly.

STEP 14. Wipe the seal with an organic solvent to remove any remaining nosing material.

STEP 15. Select the wall plate, and place it into its installed position over the seal wing on the facing wall. Using the wall plate as a template, mark the locations for the anchor holes on the facing wall (including the seal wing and the **Tack Coat - TC12** (see Figure 10). Remove the wall plate from its installed position, and drill the anchor holes into the facing wall at the marked locations.

STEP 16. Place the wall plate back into its installed position over the seal wing on the facing wall. Using the fasteners provided by the factory, attach the wall plate to the facing wall (see Figure 11).

STEP 17. Fill the gap between the wall plate and the wall with sealant (by others). Finish the surface of the sealant in accordance with good industry practice (see Figure 12).

STEP 18. Clean up the work area, removing all containers, any extra materials, debris, etc.

NOTE: THE INSTALLATION CAN BE OPENED TO TRAFFIC ONCE THE BALCO ELASTOMERIC CONCRETE - EC11 HAS FULLY CURED, APPROXIMATELY 4-6 HOURS.

SPLICING

Butt Splices of the CSL Series Winged Seal can be accomplished using one of the following two methods. Splices can be easily completed in the field by using a heat fusing process as described in METHOD I below. Splices can also be easily completed in the field using an optional adhesive splice kit and the procedures described under METHOD II below.

METHOD I - HEAT FUSING

STEP 1. Ensure that the mating ends of the seal sections to be spliced together have fresh, straight cuts.

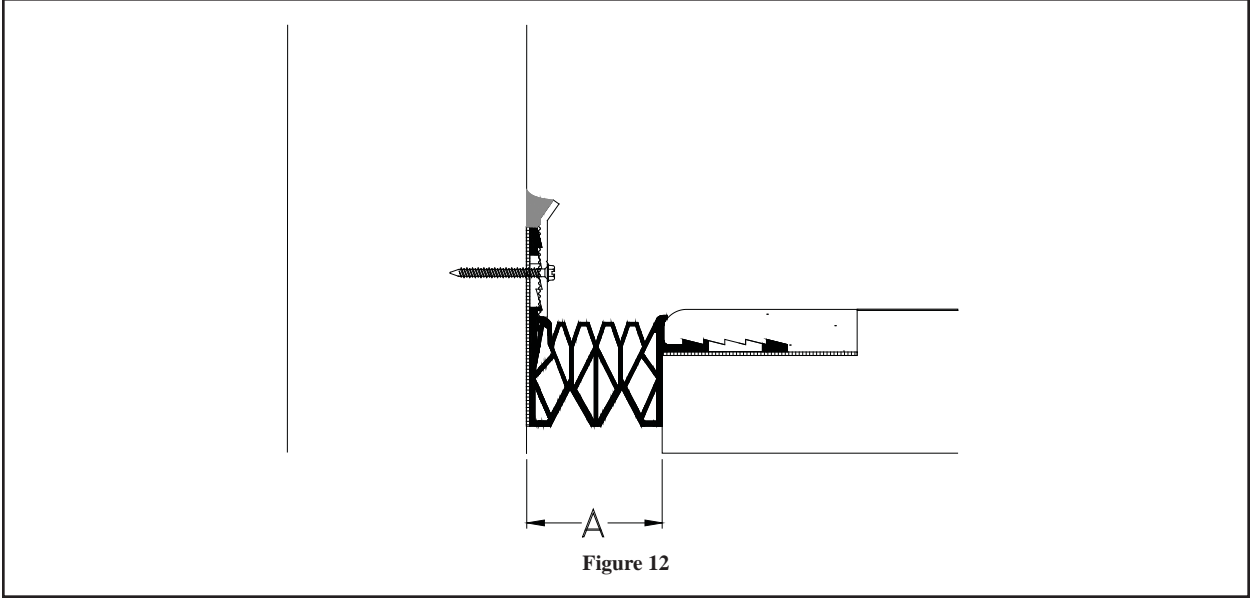
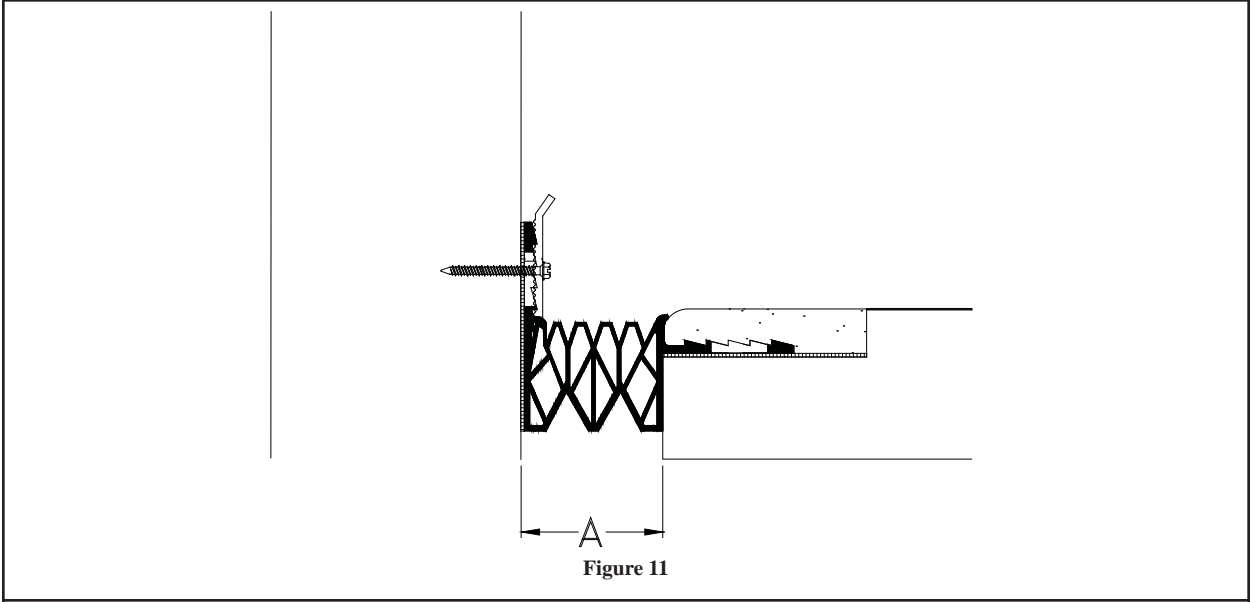
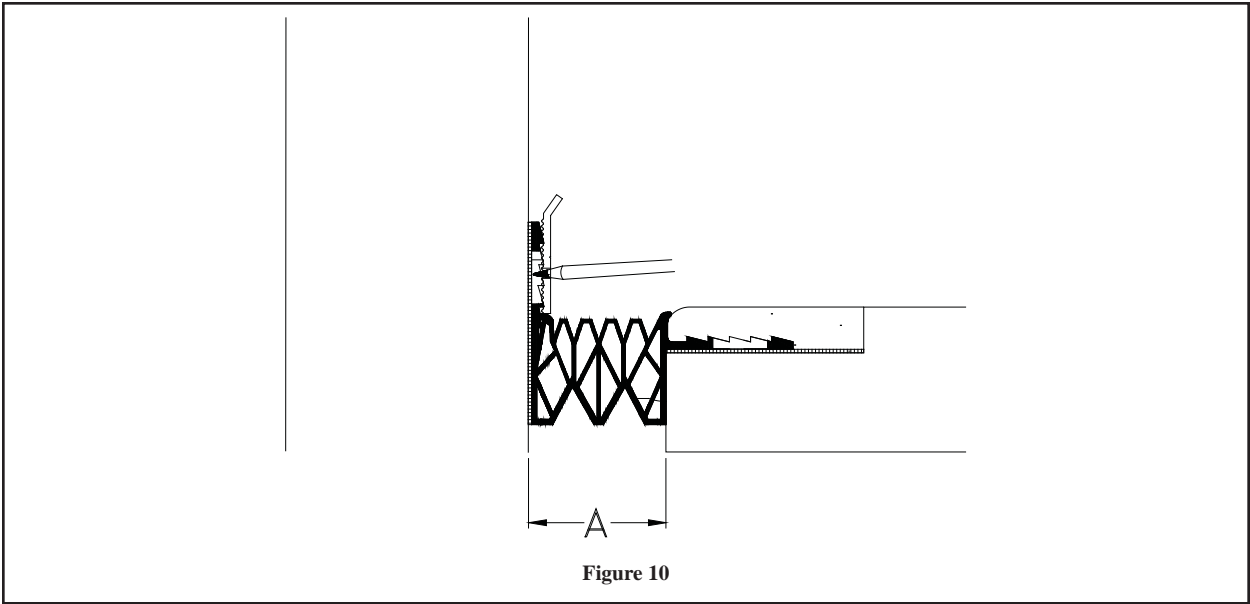

- STEP 2.** After the Splicing Iron is preheated (approximately 400°F), hold it between each end of the seal joint. Time and temperature to heat fuse seal sections together may vary depending upon seal size and environmental conditions.
- STEP 3.** When each surface shows bead of melted material, quickly remove the splicing iron, and hold the joint ends together until they bond (about 3-5 minutes). Cold water may be sprayed on the joint to expedite cooling. Do not move, bend, stretch or stress the splice before the recommended bond time.
- STEP 4.** Directional Changes in the Profile can be made by miter-cutting the seal shape and heat-splicing the material lengths together. Transitions may be fabricated in the factory or fabricated at the jobsite. Once the transition is completed, only simple buttsplicing in the field is required to incorporate the transition into the system.

METHOD II - ADHESIVE

- STEP 1.** Ensure that the mating ends of the seal sections to be spliced together have fresh, straight cuts.
- STEP 2.** Select the Adhesive Splice Kit. Using Toluene and a clean rag, clean the mating seal surfaces.
- STEP 3.** Select the Primer and the brush from the Splice Kit, and using the brush, apply the primer to the mating seal surfaces.
- STEP 4.** Select the Adhesive from the Splice Kit, and apply the adhesive to one of the mating ends.
- STEP 5.** Press the mating seal ends together and hold them together for at least one (1) minute.

ELASTOMERIC CONCRETE REPAIR

Balco, Inc. Elastomer Concrete - EC11 is a durable material. Should the EC11 crack, deteriorate or otherwise be damaged, the following procedures are for use in the repair of Elastomeric Concrete.

Preparation of the Repair Area:

- STEP 1.** Remove any loose or broken Elastomeric Concrete - EC11.
- STEP 2.** Using compressed air, blow out the area between the seal tab edge and the elastomeric concrete.
- STEP 3.** Tape off the adjoining seal and concrete areas to avoid staining.

Repair Process

- STEP 4.** Wipe down the seal and elastomeric concrete areas with a cotton rag dampened with toluene. Allow the seal and elastomeric concrete areas to dry completely.
- STEP 5.** Select the Primer 2. Mix a full unit of Balco, Inc. Primer 2.
- STEP 6.** Using a disposable brush, apply the Primer 2 to all surfaces that will interface with the new Balco, Inc. Elastomeric Concrete - EC11 being installed. Do not allow the primer to puddle.
- STEP 7.** Allow the primer to dry completely, typically 1-2 hours.
- STEP 8.** Mix a full unit of Balco, Inc. Elastomeric Concrete - EC11. If desired you may short fill the Part C aggregate to allow for a lower viscosity material that will flow and fill in the repair area. If less than the full aggregate unit is used in the mix, pre-mix the Elastomeric Concrete at the time of application, since aggregate tends to settle out of short fill mixes during transit.
- STEP 9.** Pour or place the Balco, Inc. Elastomeric Concrete into the repair area to be filled and pack into the area to ensure good compaction.
- STEP 10.** Strike off any excess material with a margin trowel assuring that the top surface is smooth and level.
- STEP 11.** Allow a minimum of 3 hours cure time before allowing traffic on the repair area.

Clean Up

- STEP 12.** Using a clean rag dampened with denatured alcohol, wipe the exposed surfaces of the seal until clean. Properly dispose of all waste materials.

WARRANTY POLICY

Balco, Inc. warrants to its purchasers that all products sold by it will be free from manufacturing and material defects. Any defective product will be replaced or repaired free of any charge, provided a claim is brought to our attention, in writing, within the established warranty period following the date of shipment by us and provided our examination shows the product has failed under the terms of this warranty. The established warranty period for exterior joint cover systems (Duraflex™) is five (5) years provided the systems are installed by a Balco Certified Installer. The established warranty period for grids and mats is two (2) years. The established warranty period for all other Balco, Inc. products is one (1) year. Balco, Inc. will not be responsible for installation costs involved in such repair or replacement. Balco, Inc. shall have no obligation under this warranty if owner subjects materials to improper conditions (refer to Balco's installation instructions) This is in lieu of all other warranties, expressed or implied, and is the sole warranty extended by Balco, Inc. Our liability under this warranty is limited to repair or replacement and does not include any responsibility for consequential or other damage of any nature. It is further agreed and understood that the price stated for the seller's products is consideration for the limitation of seller's liability hereunder.

REGISTERED TRADEMARKS:

"VINYLINES" "SAF-T-GLO"
"METAFLEX" "SAF-TEN BEVEL"
"SENTRY" "DURAFLEX"
"ILLUMI-TREAD" "METABLOCK"
"MICHAEL RIZZA COMPANY"

BALCO, INC. PATENT NUMBERS:

5,782,044; 5,829,216; 5,832,678;
6,014,848; 6,115,980; 6,581,347;
6,942,419; 6,955,017; 6,962,026;
7,104,717; 7,856,781; 7,946,784;
8,079,190; 8,245,471; 8,464,485;
8,607,519; 8,601,760; 8,646,235;
Fire Resistant Joint Covers Patents
Pending